

# TVS 6000UD

## Double Trap Isolation & Bleed Valve Station Installation & Operations Manual



Please read and save these  
instructions

# Table of Contents

General Safety Information . . . . .	3
Operation (see exploded view on page 7) . . . . .	3
Opening and Closing of the TVS Isolation Valves . . . . .	4
Opening and Closing of the Bleed Valves . . . . .	4
Strainer Blowdown Valve and Depressurization of the TVS 6000UD . . . . .	4
Testing the Operation of the Steam Trap Fitted onto the TVS 6000UD . . . . .	4
Maintenance Operation and Replacement of Steam Trap Fitted on the TVS 6000UD . .	5
<i>Closing Procedure</i> . . . . .	5
<i>Opening Procedure.</i> . . . . .	5
Troubleshooting TVS 6000UD Isolation Valves and Bleed, Test and Blowdown Valves .	6
Removing Bonnet Assembly, Valve Sealing Rings, Lantern Bushings, & Valve Washers .	7
Installing New Isolation Valve Assembly . . . . .	7
Repair Parts. . . . .	7
Limited Warranty and Remedy . . . . .	8

# General Safety Information

This manual shall be used by experienced personnel only as a guide for installation and maintenance of the TVS 6000UD Trap Valve Station Series. Selection or installation of equipment should always be accompanied by competent technical assistance. We encourage you to contact Armstrong International or its local Representative if further information is required.

Equipment under pressure – operating at temperatures >212 °F/100 °C – make sure that all components (TVS and trap) are cold before handling.

## Icon Legend



**CAUTION!**

**Potential property damage, expensive repairs, and/or voiding the equipment warranty may result.**



**BURN HAZARD!**

**Contact with steam, hot water, or hot metal surfaces can cause severe skin burns. Skin exposure to 140°F (60°C) water or metal for only five (5) seconds may cause a second degree burn.**

TVS6000UD is a trap valve station designed to operate with a two-bolt steam trap.

Before installing the steam trap on the TVS6000UD, remove the self-adhesive sticker that is blocking the holes. This cap is used to protect the product from dirt during painting operation, transportation and before installation.

## Operation (see exploded view on page 7)

In a double piston valve, the control of stem and seats leakage is obtained by tightness of valve sealing rings (3) to the body and valve plugs (5). The bonnet compresses the valve sealing rings against the body and the valve plugs. Flexible disc springs (7) automatically assure a tight seal by exerting pressure on the valve sealing rings, keeping them compressed.



TVS6000UD with sticker as delivered.



Remove the self-adhesive sticker before to install steam trap.



TVS6000UD without sticker  
TVS 6000UD is ready for the trap installation once self-adhesive sticker is removed.

# Opening and Closing of the TVS Isolation Valves

The arrows on the hand wheels clearly indicate the direction to which the hand wheels must be operated (“+” to open and “-” to close)

The isolation valves A-A’ (upstream marked with red washer) and G-G’ (downstream marked with green washer) begin to stop the flow when the valve plugs enter the upper valve sealing ring (3).

To play its role of double isolation valve, the plug must be moved downward until it closes the lower valve sealing ring (3) and valve stroke is achieved. This isolation valve is completely closed/opened when the hand wheel is screwed/unscrewed at the end of the stroke.

When the isolation valves are completely closed, the valve plug is in full contact with the valve sealing rings, ensuring the best possible seal. Since there is no metal to metal seating, torquing the isolating valves closed is not required. Armstrong recommends that after closing the isolation valve completely, the hand wheel should be turned back one-half turn. This makes it easy to re-open the valve after prolonged periods of no use.

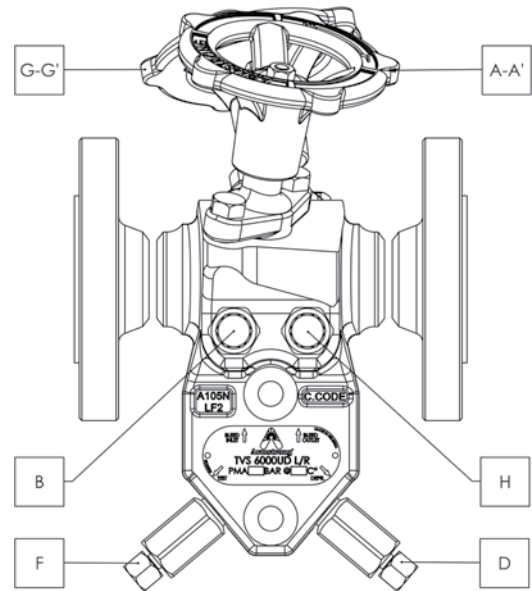

Model L/R\*

\* Label is for information, only the information engraved on the body of the TVS is authentic and determines flow direction.

# Opening and Closing of the Bleed Valves

The role of the bleed valves in the TVS 6000UD is to allow safe and quick replacement of the connected steam trap. When the 2 isolation valves are closed, if there is any leakage from the isolation points it will be visible and divert to the atmosphere through the opened bleed valves, i.e. upstream (A-A’) or downstream (G-G’) isolating valves.

This allows any leaks to be visualized and any potentially dangerous working conditions avoided during maintenance. The 2 bleed valves will be opened and closed with a flat wrench (13 mm) with a torque of 55-68 N-m.

# Strainer Blowdown Valve and Depressurization of the TVS 6000UD

The TVS 6000UD is supplied with a built-in strainer designed to protect more sensitive steam traps against dirt normally present in steam systems. The strainer is fitted with a blowdown valve (D) used to clean the screen on a regular basis. This blowdown valve can be used at start-up to eliminate the larger amount of condensate generated into the atmosphere.



**BURN HAZARD!** Hot condensate and flash steam will be discharged from the test port. Use caution as burns could occur to personnel. During this operation, the downstream isolation (G-G’) is normally closed. The same blowdown valve is also used as a depressurizing valve when needed (during the replacement procedure of the steam trap). In this case, both isolation valves (A-A’) and (G-G’) are to be closed and bleed valves (B and H) are to be open to atmosphere.

# Testing the Operation of the Steam Trap Fitted onto the TVS 6000UD

- Keep the upstream isolating valve (A-A’) open
- Close the downstream isolation valve (G-G’)
- Open test valve (F). Its location is indicated on the name plate
- Observe the steam trap operation at test port



**BURN HAZARD!** Hot condensate and flash steam will be discharged from the test port. Use caution as burns could occur to personnel.

- Re-open the isolation valve (G-G’) after closure of the test valve (F) with a flat wrench (13 mm) with a torque of 55-68 N-m.

# Maintenance Operation and Replacement of Steam Trap Fitted on the TVS 6000UD

In case the steam trap must be replaced for any reason, please apply the safety procedure as follows:

## Closing Procedure

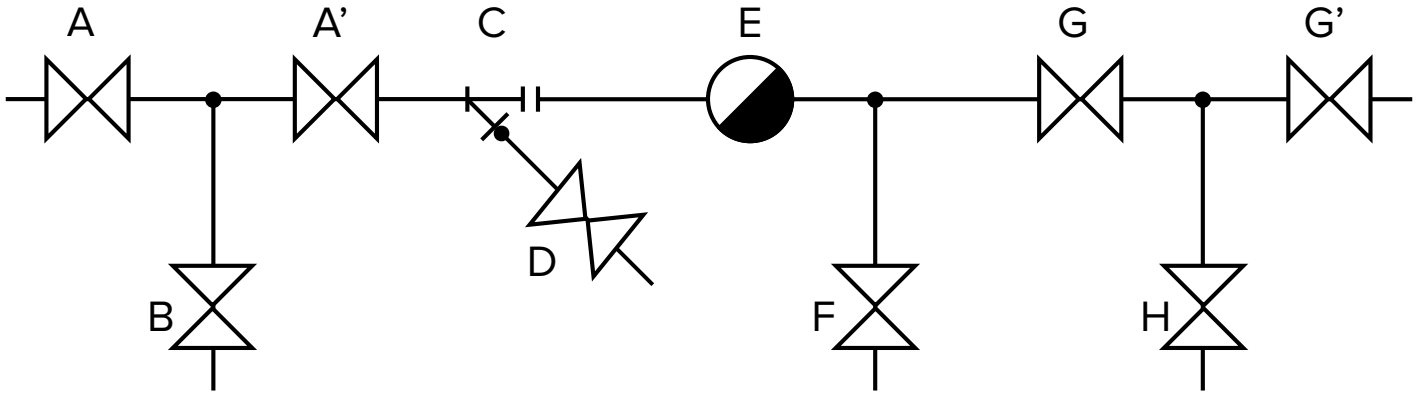

**BURN HAZARD!** Use caution as burns could occur to personnel.

Close A-A', G-G'

Open B, H, F, D

- After pressure has been relieved, remove bolts and the trap
- Clean the connector block sealing surfaces
- Apply "Never seize" to the new trap bolts (2), insert bolts through connector block making sure the trap is properly positioned (per ex: inverted bucket in the vertical position). Tighten bolts with socket wrench evenly with a torque of 55-80 N-m
- Resume normal (steam) operation. Please apply the safety procedure as follows:

## Opening Procedure

- Close B, D
- Open A-A'
- Check that the steam trap is working properly
- Close F, H
- Open G-G'
  - Check for leaks around the connector block

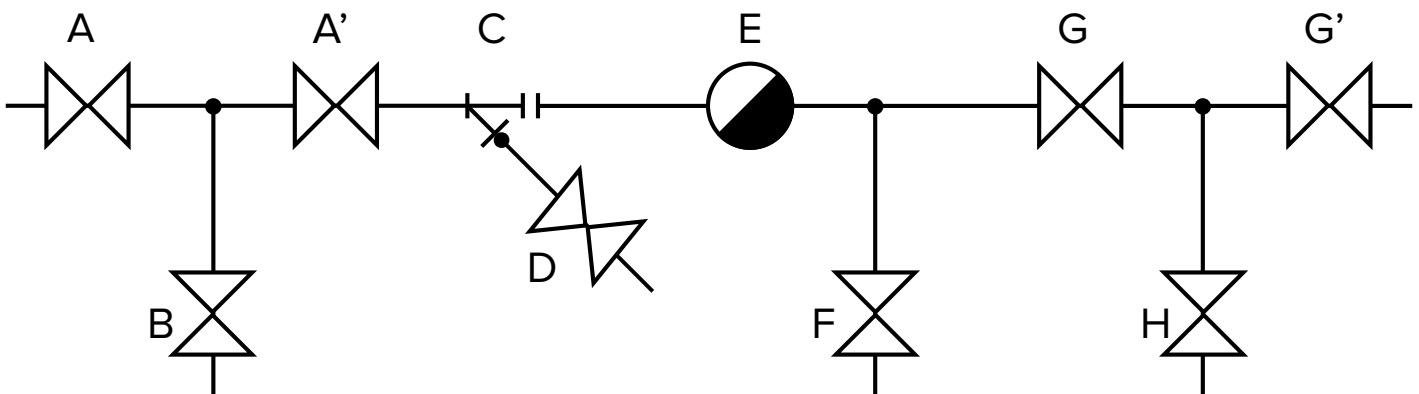

# Troubleshooting TVS 6000UD Isolation Valves and Bleed, Test and Blowdown Valves

A piston valve will retain its leak tightness for several years without maintenance. In severe service such as rapid heating and cooling, some field maintenance may be required. Depending on the problem, these simple steps may help:

- Isolation valve(s) (A-A' and/or G-G') leak when the valve(s) is(are) closed.
  - First, check to make sure the isolation valves are completely closed. Then, check to see if the bonnet is seated on the body of the connector block. If not, tighten the bonnet bolts until the bonnet seats. This will allow the bonnet bolts to compress the valve sealing rings against the body and the valve plug. If the valve(s) continue to leak, replace the isolation valve assembly.
- Valve stem leaks.
  - See above instructions.
- Maintain the isolation valves as soon as leakage starts. Internal leakage can wear the valve plug or valve sealing rings and they will have to be replaced if leakage continues.



**CAUTION!** Before tightening the bonnet bolts, ensure the isolation valve is in the closed position.

- Bleed (B&H), test (F) and blowdown (D) valves leak. Reseat with 55-80 N-m torque.

# Removing Bonnet Assembly, Valve Sealing Rings, Lantern Bushings, & Valve Washers

	Description	Quantity
1	Bonnet TVS CS A105N/LF2 (D8563)	1
2	Handwheel TVS/Manif DI (D126073)	1
3	Ring Val TVS4000 GPH + SS (B5028)*	3
4	Bushing Lantern SS T303 (B5019)*	1
5	Stem Val TVS6000 SS 17-4PH (D125134)	1
6	Bolt Hex M8 X 1.25 x 25mm CS (B5035)	2
7	Washer Flat ID SS T304 (B5033)	2
8	Nut Hex M6X1 SS 17-4PH (B5022)	1
9	Spring Disc (B5031)*	7
10	Washer Flat 10.5mm ID SS T304 (B5029)	4
11	Bushing Lantern TVS6000 SS T303 (D125140)*	1
12	Disc TVS 6000UD OD 26 X ID 8 X thick 0.5 mm: Red (D125703) for the inset isolation valve or Green (D125702) for the outlet isolation valve	1

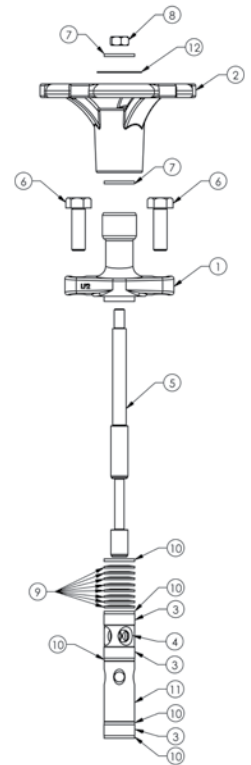

(\*) part of Seal and Mech Assembly (D125704)

- This can be done with the TVS 6000UD remaining in the steam line.
- Be sure to isolate the TVS 6000UD trap valve station both up and downstream by using separate shut-off valves before performing any maintenance.
- Open isolation valves (A-A') and (G-G').
- Open bleed valve (B&H) to atmosphere.
- Open the blowdown/depressurizing (D) to atmosphere.
- Loosen and remove the bonnet bolts and pull the bonnet assembly out of the valve body.
- Remove the valve sealing rings, valve washers and lantern bushings using Armstrong extracting tool. Check to see if all components have been removed. Inspect and clean any debris that might have remained in the valve body.



**CAUTION!** This applies to all points above: equipment under pressure – operating at temperature > 212 °F/100 °C – ensure all components (TVS and trap) are cold before handling.

## Installing New Isolation Valve Assembly

- Place Armstrong spare part # D125139 isolation valve assembly in the valve body
- Lightly tap the isolation valve assembly to the bottom of the valve body
- Coat the threads of the bonnet bolts with “Never Seize”, insert bolts through bonnet holes and tighten evenly until the bonnet seats on the valve body
- Check the TVS 6000UD isolation valve for proper operation by opening and closing the valve one or two times
- Open shut-off valves up and downstream from the trap valve station with its isolation valve in the closed position and check for leaks with trap installed
- Follow the opening and closing sequences as explained on page 5

## Repair Parts

- Packing assembly TVS6000 SST303 (D125139)
- Seal and Mech TVS 6000UD (D125704)
- Valve NBD assembly ¼ MNPT TVS6000SST303 3.1 (D125135)

Designs, materials, weights and performance ratings are approximate and subject to change without notice.  
Visit [armstronginternational.com](http://armstronginternational.com) for up-to-date information.

North America • Latin America • India • Europe / Middle East / Africa • China • Pacific Rim  
[armstronginternational.com](http://armstronginternational.com)

# Limited Warranty and Remedy

Armstrong International, Inc. or the Armstrong division that sold the product (“Armstrong”) warrants to the original user of those products supplied by it and used in the service and in the manner for which they are intended, that such products shall be free from defects in material and workmanship for a period of one (1) year from the date of installation, but not longer than 15 months from the date of shipment from the factory, [unless a Special Warranty Period applies, as listed below]. This warranty does not extend to any product that has been subject to misuse, neglect or alteration after shipment from the Armstrong factory. Except as may be expressly provided in a written agreement between Armstrong and the user, which is signed by both parties, **ARMSTRONG DOES NOT MAKE ANY OTHER REPRESENTATIONS OR WARRANTIES, EXPRESS OR IMPLIED, INCLUDING, BUT NOT LIMITED TO, ANY IMPLIED WARRANTY OF MERCHANTABILITY OR ANY IMPLIED WARRANTY OF FITNESS FOR A PARTICULAR PURPOSE.**

The sole and exclusive remedy with respect to the above limited warranty or with respect to any other claim relating to the products or to defects or any condition or use of the products supplied by Armstrong, however caused, and whether such claim is based upon warranty, contract, negligence, strict liability, or any other basis or theory, is limited to Armstrong’s repair or replacement of the part or product, excluding any labor or any other cost to remove or install said part or product, or at Armstrong’s option, to repayment of the purchase price. As a condition of enforcing any rights or remedies relating to Armstrong products, notice of any warranty or other claim relating to the products must be given in writing to Armstrong: (i) within 30 days of last day of the applicable warranty period, or (ii) within 30 days of the date of the manifestation of the condition or occurrence giving rise to the claim, whichever is earlier. **IN NO EVENT SHALL ARMSTRONG BE LIABLE FOR SPECIAL, DIRECT, INDIRECT, INCIDENTAL OR CONSEQUENTIAL DAMAGES, INCLUDING, BUT NOT LIMITED TO, LOSS OF USE OR PROFITS OR INTERRUPTION OF BUSINESS.** The Limited Warranty and Remedy terms herein apply notwithstanding any contrary terms in any purchase order or form submitted or issued by any user, purchaser, or third party and all such contrary terms shall be deemed rejected by Armstrong.



© Armstrong International, Inc  
889-EN V1.9 03/2022

Designs, materials, weights and performance ratings are approximate and subject to change without notice.  
Visit [armstronginternational.com](http://armstronginternational.com) for up-to-date information.

North America • Latin America • India • Europe / Middle East / Africa • China • Pacific Rim  
[armstronginternational.com](http://armstronginternational.com)