

SH-300, SH-900, SH-1500, SH-1600 and SH-1700 Bimetallic Steam Trap Installation and Operation Manual

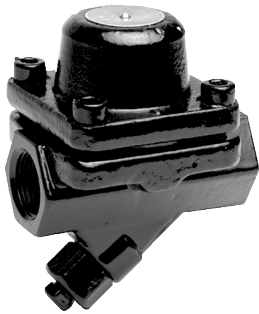

SH-300



SH-900



SH-1500

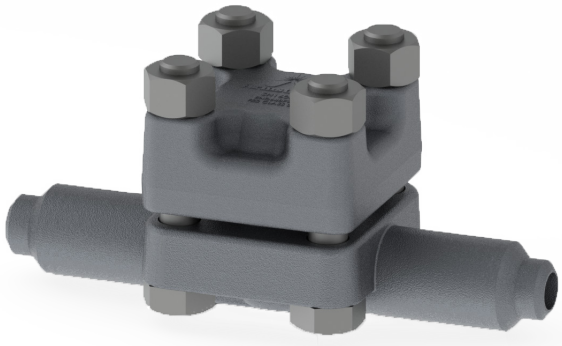

SH-1600

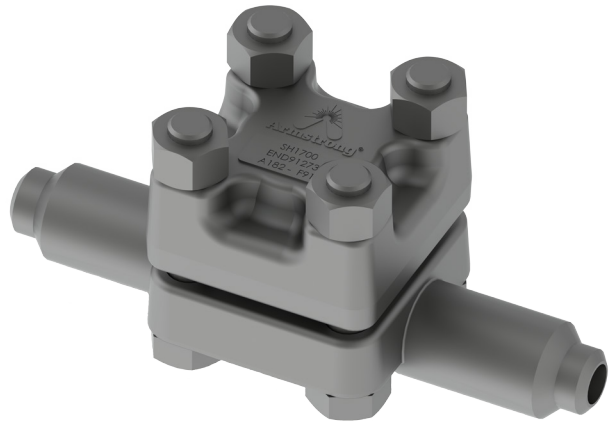

SH-1700

Table of Content

- General Safety Information3
- Product Information4
- Product Installation5
- Service and Maintenance.7
- Troubleshooting8
- Repair Procedure9
- Warranty Terms10

General Safety Information

 **Warning:** This bulletin should be used by experienced personnel as a guide to the installation and maintenance of the Armstrong SH-300, SH-900, SH-1500, SH-1600 and SH-1700 Bimetallic Steam Traps. Selection or installation of equipment should always be accompanied by competent technical assistance. We encourage you to contact Armstrong International or your local representative if further information is required.

©2017 Armstrong International, Inc.

Designs, materials, weights and performance ratings are approximate and subject to change without notice.

Product Information

1. Product Information:

Bimetallic type steam traps employ the temperature effect of a thermostatic bimetallic element. At start up, the steam traps have the ability to handle large condensate loads while the system is heating up. At this point the bimetallic element is contracted and the valve is fully open removing condensate and non-condensable gases from the system. When the system reaches steam temperature, the high temperature causes the bimetallic element to expand, pulling the valve stem to close the valve. The valve remains closed until enough condensate backs up cooling the bimetallic element. As the bimetallic element cools, the valve slightly opens to pass condensate and vent non-condensable gases. When steam temperature is achieved, the valve closes again.

Product Installation

2. Installing a SH-300, SH-900, SH-1500, SH-1600 and SH-1700

Before installation, verify that the maximum allowable pressure/temperature and maximum operating pressure of the trap are sufficient to handle the system design pressure and temperature. This information can be found on the label located on the trap.

Steam trap installation is critical from both a performance and maintenance aspect. Installation of the trap is simplified if you follow these guidelines.

1. Before installing the trap, ensure the line is clean. Blow down any strainers ahead of the trap.
2. Install the trap so that it is accessible for inspection and repair, below the drip point and close to the vertical drip leg.
3. For proper operation the trap should be installed in the horizontal line with the domed cap in the up position.
4. What little condensate there is on superheat and high pressure/low load service usually forms in drip legs and in the trap themselves. Therefore, proper piping and drip legs of adequate size and diameter are essential for the successful operation of the Armstrong bimetallic traps, see Chart 2.1 and Figure 2.1.
5. Isolation valves are needed before and after traps. When starting a new trap, be sure to open the valve slowly.
6. Due to the high temperatures of steam, it might be necessary to guard the traps for personnel safety.
7. See Figures 2.1 and 2.2 for complete installation following the above guidelines.

M		D		H			
				Drip Length Minimum			
Steam Main Size		Drip Leg Diameter		Supervised Warm-Up		Automatic Warm-Up	
in	mm	in	mm	in	mm	in	mm
1/2	15	1/2	15	10	250	28	710
3/4	20	3/4	20	10	250	28	710
1	25	1	25	10	250	28	710
2	50	2	50	10	250	28	710
3	75	3	75	10	250	28	710
4	100	4	100	10	250	28	710
6	150	4	100	10	250	28	710
8	200	4	100	12	300	28	710
10	250	6	150	15	380	28	710
12	300	6	150	18	450	28	710
14	350	8	200	21	530	28	710
16	400	8	200	24	600	28	710
18	450	10	250	27	685	28	710
20	500	10	250	30	760	30	760
24	600	12	300	36	910	36	910

Table 2.1

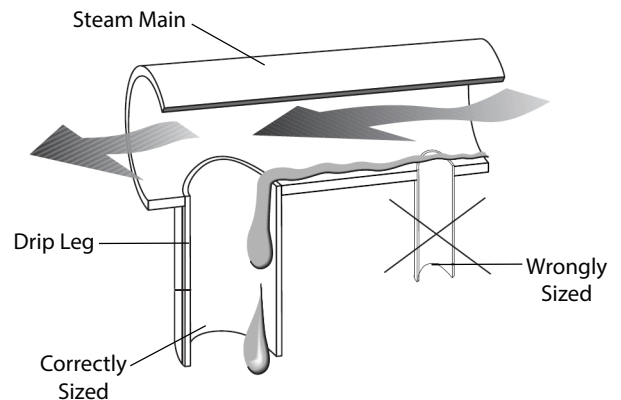
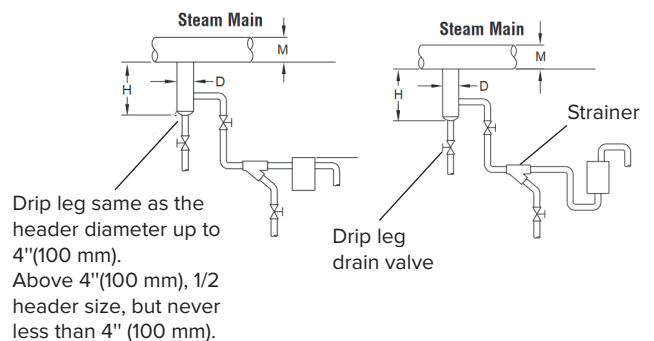

Figure 2.1



Drip leg same as the header diameter up to 4" (100 mm). Above 4" (100 mm), 1/2 header size, but never less than 4" (100 mm).

Figure 2.2

2.1. Disassemble/Assemble Procedure for Welding SH-300, SH-900, SH-1500, SH-1600 and SH-1700 – If post weld heat treat is required by customers' weld procedure.

1. Remove 4 flange bolts and cap.
2. Remove bimetallic element assembly using a 1" (38 mm) open end wrench on hex below the bimetallic elements.
3. Preheat, weld and post weld heat treat per customers weld procedure.
4. Clean gasket surfaces and replace gasket with a new one.
5. Replace bimetallic element assembly using the 1" (38 mm) open end wrench. Torque to 100 to 125 ft-lbs., [136 to 170 Nm].
6. Replace cap and flange bolts
7. Torque the flange bolts with a 3 or 4 step crisscross pattern to 280 ft-lbs., [380 Nm] for the SH-1500, SH-1600 & SH-1700 and to 90 ft-lbs., [122 Nm] for the SH-900.

Service and Maintenance

3. Service and Maintenance

Bimetallic type steam traps should be tested at least three times per year. When the bimetallic steam trap is suspected of malfunctioning, it can be checked by observing the discharge of the trap. Normal trap operation would be indicated by:

- Trap discharging condensate continuously (modulating)
- Trap discharge in cycles (on-off)

All discharges are accompanied by large amounts of flash steam.

Do not confuse the discharge of flash steam with live steam loss. If the trap continues to blow live steam, isolate the trap and repair or replace. See disassembly/assembly procedure in Product Installation section for repair.

Troubleshooting

4. Troubleshooting

Whenever a trap fails to operate and the reason is not readily apparent, the discharge from the trap should be observed. If the trap is installed with a test outlet or discharges to atmosphere, this will be a simple matter - otherwise, it will be necessary to break the discharge connection.

4.1. Cold Trap - No Discharge

No condensate or steam coming to trap.

- Stopped or plugged strainer ahead of trap
- Broken valve in line to trap
- Pipeline or elbows plugged
- Pressure reducing valve out of order
- Isolation valves are off/closed

 **Caution:** Superheated steam is invisible. Do not place objects directly in the path of trap discharge. In a blow through situation a loud roar should be heard even though there may not be visible steam

4.2. Steam Loss

If the trap leaks or blows live steam, trouble may be due to any of the following causes:

- Valve may fail to seat
- Piece of scale lodged in orifice
- Worn parts

Perceived Troubles: If it appears that steam escapes every time trap discharges, remember that hot condensate forms flash steam when released to lower pressure, but usually condenses quickly in the return line.

4.3. Continuous Flow

- Trap not up to temperature. Allow more time for condensate removal (on start-up)
- On large loads the traps is working fine as designed.

Repair Procedure

5. Repair of SH-300, SH-900, SH-1500, SH-1600 and SH-1700

5.1. TRAP



Caution: Superheat steam is invisible. Take extra precaution while inspecting traps.

Caution: Superheat steam is invisible. Take extra precaution while inspecting traps.

- Isolate the trap
- Blowdown/bleed off the internal pressure
- Unbolt and remove the cap
- Place 1" (38 mm) open end wrench on the hex below the elements and unscrew the assembly
- Remove the old gasket from the body and cap seating surface
- Clean or replace the screen
- Install a new gasket on the body seating surface
- Install screen
- Replace the element assembly using a 1" (38 mm) open end wrench on the hex surface. Torque to 100 – 125 ft-lbs., [136 to 170 Nm].
- Reassemble the cap into the body seating surface recess
- Reassemble bolts and nuts
- Torque the flange bolts with a 3 or 4 step crisscross pattern to 280 ft-lbs., [380 Nm] for the SH-1500, SH-1600 & SH-1700 and to 90 ft-lbs., [122 Nm] for the SH-900.

When starting a trap, be sure to open the isolation valves slowly and check for gasket leaks.

5.2. Repair Parts

- Cap
- Body
- Element
- Screen
- Gasket
- Bolt Set

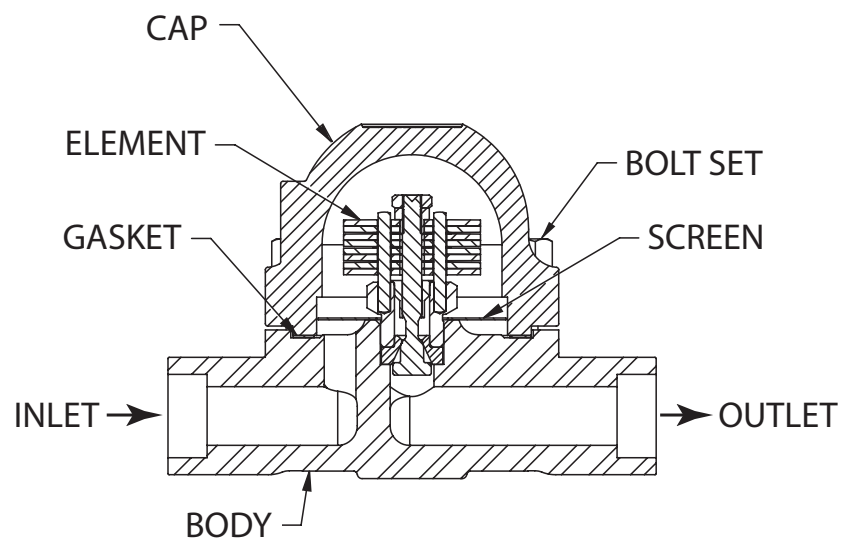

Figure 5.1 Repair parts for SH-300/SH-900/
SH-1500/SH-1600/SH-1700

Limited Warranty and Remedy

6. Warranty Terms

Armstrong International, Inc. or the Armstrong division that sold the product (“Armstrong”) warrants to the original user of those products supplied by it and used in the service and in the manner for which they are intended, that such products shall be free from defects in material and workmanship for a period of one (1) year from the date of installation, but not longer than 15 months from the date of shipment from the factory, [unless a Special Warranty Period applies, as listed below]. This warranty does not extend to any product that has been subject to misuse, neglect or alteration after shipment from the Armstrong factory. Except as may be expressly provided in a written agreement between Armstrong and the user, which is signed by both parties, Armstrong **DOES NOT MAKE ANY OTHER REPRESENTATIONS OR WARRANTIES, EXPRESS OR IMPLIED, INCLUDING, BUT NOT LIMITED TO, ANY IMPLIED WARRANTY OF MERCHANTABILITY OR ANY IMPLIED WARRANTY OF FITNESS FOR A PARTICULAR PURPOSE.**

The sole and exclusive remedy with respect to the above limited warranty or with respect to any other claim relating to the products or to defects or any condition or use of the products supplied by Armstrong, however caused, and whether such claim is based upon warranty, contract, negligence, strict liability, or any other basis or theory, is limited to Armstrong’s repair or replacement of the part or product, excluding any labor or any other cost to remove or install said part or product, or at Armstrong’s option, to repayment of the purchase price. As a condition of enforcing any rights or remedies relating to Armstrong products, notice of any warranty or other claim relating to the products must be given in writing to Armstrong: (i) within 30 days of last day of the applicable warranty period, or (ii) within 30 days of the date of the manifestation of the condition or occurrence giving rise to the claim, whichever is earlier. **IN NO EVENT SHALL ARMSTRONG BE LIABLE FOR SPECIAL, DIRECT, INDIRECT, INCIDENTAL OR CONSEQUENTIAL DAMAGES, INCLUDING, BUT NOT LIMITED TO, LOSS OF USE OR PROFITS OR INTERRUPTION OF BUSINESS.** The Limited Warranty and Remedy terms herein apply not withstanding any contrary terms in any purchase order or form submitted or issued by any user, purchaser, or third party and all such contrary terms shall be deemed rejected by Armstrong.

Notes

Armstrong provides intelligent system solutions that improve utility performance, lower energy consumption, and reduce environmental emissions while providing an “enjoyable experience.”



Armstrong International

North America • Latin America • India • Europe / Middle East / Africa • China • Pacific Rim

armstronginternational.com