

DIMENSIONS & DATA CERTIFIED FOR:

Representative:

Order:

Customer:

Order:

Project:

Requirements:

By:

Date:

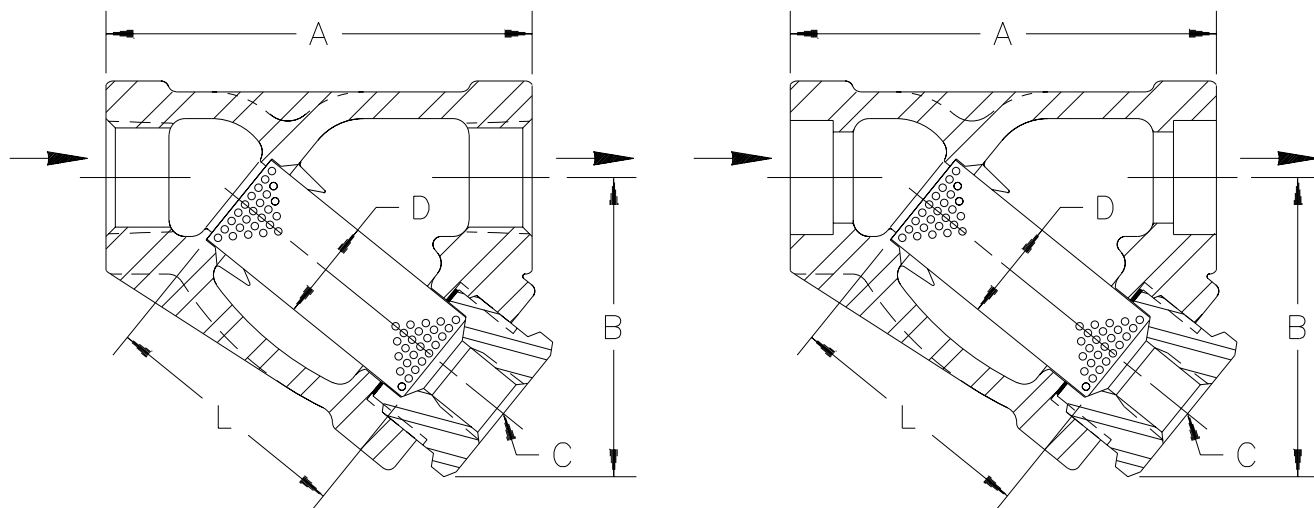

C1SC

C1SW

1" Strainers shown above

Socket Weld Conn. ANSI B16.11
Dimensions A & B ±1/8" [3mm]

DESCRIPTION	DIMENSIONS		
CONNECTION (NPT & SW)	1/2" [DN15]	3/4" [DN20]	1" [DN25]
"A" (FACE TO FACE)	3-23/32" [94mm]	4-3/16" [106mm]	4-31/32" [127mm]
"B" (BOTTOM TO ϕ INLET)	2-11/16" [68mm]	2-15/16" [75mm]	3-1/2" [89mm]
"C" (BLOW DOWN THREAD)	3/8" NPT [DN10]	1/2" NPT [DN15]	
"D" (DIA. OF SCREEN)	13/16" [21mm]	31/32" [25mm]	1-3/16" [30mm]
"L" (LENGTH OF SCREEN)	2-1/16" [52mm]	2-3/8" [60mm]	2-15/16" [75mm]
WEIGHT	2-1/2 lb [1.1 kgs]	3-1/2 lb [1.6 kgs]	5-1/2 lb [2.5 kgs]
MAXIMUM ALLOWABLE PRESSURE (VESSEL DESIGN)	2090 psig at 643°F [144 bar at 339°C] 3000 psig at 100°F [207 bar at 37.8°C]		

LIST OF MATERIALS	
NAME OF PART	MATERIAL
BODY	ASTM A217 GR. WC6
SCREEN	T304 SS .045" PERF.
GASKET	SOFT STEEL
RETAINER	ASTM A276



Armstrong International, Inc.
Three Rivers Division
Three Rivers, MI 49093
Armstrong (616) 273-1415 Fax(616) 278-6555

Product	CD No.	Date
STRAINER C1SC & C1SW 1/2" - 1" WC6	1055	1/20/97
		Rev. B